

OPEN ACCESS

Compression-after-impact (CAI) performance of epoxy-carbon fibre-reinforced nanocomposites using nanosilica and rubber particle enhancement

To cite this article: B Nikfar and J Njuguna 2014 *IOP Conf. Ser.: Mater. Sci. Eng.* **64** 012009

View the [article online](#) for updates and enhancements.

Related content

- [A review on the effect of mechanical drilling on polymer nanocomposites](#)
Kristof Starost and James Njuguna
- [Energy absorption characteristics of nano-composite conical structures](#)
F Silva, S Sachse and J Njuguna
- [Effect of silica nanoparticles on polyurethane foaming process and foam properties](#)
A B Francés and M V Navarro Bañón

Recent citations

- [Compression after impact characteristics of carbon fiber reinforced aluminum laminates](#)
Gurpinder S. Dhaliwal and Golam M. Newaz
- [Impact damage in SiO₂ nanoparticle enhanced epoxy – Carbon fibre composites](#)
M. Landowski *et al*

Compression-after-impact (CAI) performance of epoxy-carbon fibre-reinforced nanocomposites using nanosilica and rubber particle enhancement

B Nikfar¹ and J Njuguna²

¹Department of Automotive Engineering, Polytechnic of Turin, Turin, Italy

²IDEAS Research Institute, School of Engineering, Robert Gordon University, Aberdeen; Riverside East, Garthdee Road, Aberdeen AB10 7GJ, United Kingdom

Email: behzad.nikfar@studenti.polito.it; j.njuguna@rgu.ac.uk

Abstract. One of the problems in the design of automotive structures and body parts made by fibre reinforced composites is that these materials are susceptible to a small energy impact caused by for instance, accidental tool drop during maintenance or stone strike while in operation. This often lead to a barely visible impact damage which causes reduction in compressive strength of the composite part. To increase the impact tolerance of the composites, toughening agents like silica nanoparticles and rubber particles can be utilized to toughen the resin. To understand the effect of the particles enhancement, the impact tolerance was evaluated utilizing Compression After Impact (CAI) test after the impact induced by gas-gun impacting equipment. The results from CAI test after 20 J impact (high energy stone strike) shows about 30% improvement in residual compressive strength for the nanosilica enhanced composite compared to unmodified CFRP. Also C-scan results after 7 J impact shows about 50% smaller delamination area for the nano-enhanced composite.

1. Introduction

Polymer composites but composites can have very good energy absorption even better than metals if properly tailored. However, one of the problems in the design of structures and body parts made by carbon fibre reinforced composites (CFRC) is that these materials are susceptible to a small energy impact accidentally which may cause delaminations through the thickness. Dropped tool or stone strike can cause low-energy impact on race cars body and structures which results in significant reductions in residual compressive strength. The induced damage is called “barely visible impact damage” (BVID) and is a potential source of mechanical weakness of chassis and structures and reduces aerodynamic efficiency of the body parts (like the rear wing) since the efficiency of the different aerodynamic devices depends on boundary layers at the surface and the part’s strength for inducing downforce [1].

To evaluate the composite’s performance after a BVID caused by an accidental impact, the compression after impact (CAI) test is used. To improve the damage tolerance of structures, the constituents of the composite and their effects on impact tolerance should be studied. Most of the experiments to improve damage tolerance of composites were concentrated on either producing high strength fibres or toughening the resin matrix [1]. The effect of toughening agents is to increase the work of fracture within the composite. One of the methods to increase toughness of resin matrix like



epoxy is to add nanoparticles like SiO₂ nanoparticles with rubber particles to the resin matrix. This modifications of epoxy resins could cause some superior properties improvements like broadening of the glass transition temperatures, modest increases in the glassy modulus, low dielectric constant, and significant increases in key mechanical properties [2].

The experimental data presented here are from an investigation of the toughening effect of nanosilica particles on carbon fibre reinforced epoxy on damage caused by low and high velocity impacts. The delamination area was measured using C-scan ultrasonic techniques. Finally, the effects of the toughening agents in the matrix of the composite and the single and double step impacts on the CAI strength were investigated.

2. Experimental

2.1. *Materials and Sample Manufacturing*

Nanosilica (silica particles of the order 20nm diameter) enhanced epoxy-carbon fibre-reinforced samples and unmodified epoxy ones were manufactured. The two type resins were cured with a hardener and manufactured by vacuum injection moulding. The resins and hardener were blended together and the mixture was then injected into a mould using a vacuum at 70°C and cured in an oven for 2 hrs at 160°C and then rested at 40°C for 8 hrs to form the composites flat plates of 4 mm thickness. 8 unidirectional carbon fiber plies were used with stacking sequence of $[45^{\circ}/0^{\circ}/-45^{\circ}/90^{\circ}]_s$ as indicated in ASTM D7137 standard for CAI test. The volume fraction of the fibre was 55.7% (matrix volume fraction of 44.3%). The composite plates were then cut into 150x100 mm sections for impact testing as required in ISO 18352.

2.2. *Impact Testing*

Impact testing gives an indication of how a material will perform during a dynamic loading condition. The impact to be simulated is a stone strike vehicular composite structure. Experimental impact tests are carried out using a gas gun. Gas gun impact tester employs a 10 mm hemi-spherical 22 g projectile (simulating flying granite stone impact scenario) and has been conducted by adjusting the pressure in the gun to reach the desired impact velocity at 90 degrees angle to the impact surface. Single step impacted sample were impacted only at 20 J. Double step impacted samples were impacted in two steps: first step (7.5 J) and second step (20 J). For consistency, five samples were tested in each test. Ultrasonic C-scans were used to evaluate the damage.

2.3. *Compression after Impact (CAI) Test*

Residual compressive strength of polymer composites laminates damaged by an impact was evaluated using ASTM D7137 standard. This test is valid for multidirectional continuous fibre reinforced composite laminates which are symmetric and balanced with respect to the test direction [4]. A uniaxial compression test is performed using a balanced, symmetric laminated plate, which has been damaged and inspected prior to the application of compressive force. The damage state is imparted through out-of-plane loading caused by ballistic gas gun impact.

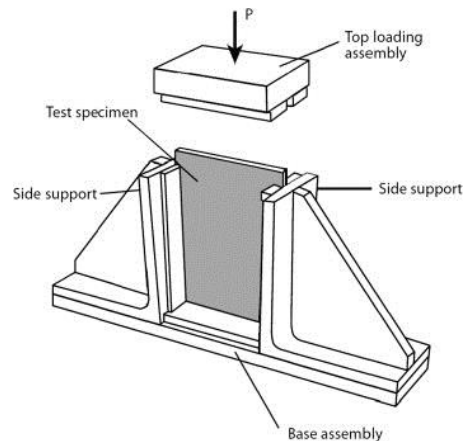

Figure 1. Schematic of compressive residual strength support fixture with specimen in place.

3. Results and Discussion

3.1. Impact results

Typical results from the C-scan results for epoxy/CFRC and SiO_2 /rubber/epoxy CFRC after the first step impact simulating the low energy tool drop impact can be seen in Figure 3 and 4. The blue-white area indicates damage in that area which is the hit area of the projectile. Probably in the white area fibre breakage and delaminations exist in almost all interfaces through the thickness of the laminate and the blue area corresponds to splitting and delaminations of the back-face rather than internal damage. The areas with yellow colour indicate some possible additional damages. It can be obviously seen in the C-scan images that the delamination area diameter for the nanosilica enhanced samples is significantly smaller than that for the non-nano enhanced samples. Greater fracture energy is required for delamination initiation and growth for toughened epoxy composite.

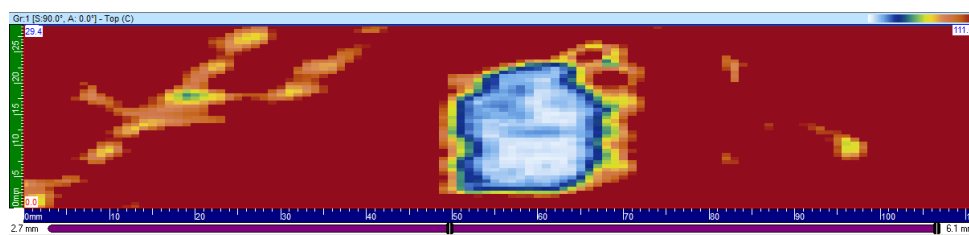

Figure 3. Ultrasonic C-scan for epoxy/CFRC typical sample.

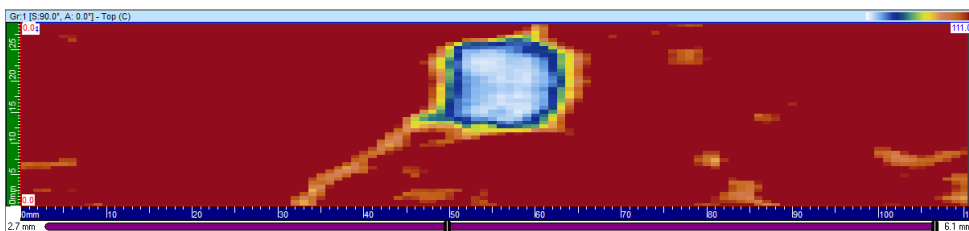

Figure 4. Ultrasonic C-scan images for SiO_2 /rubber/epoxy CFRC typical sample.

Further examination of the impacted specimens after second impact and although visible damages were observed after first impact to the naked eye inspection, both samples suffered from cracks damage at second impact. It is well known that the first step of the damage caused by an impact is matrix cracks which are generated by shear or tensile stresses mainly in the intermediate or back-wall layers, then delaminations grow from the crack tips between layers (Figure 5). This would mean that after the high energy second step impact, the damage area had increased and the cracks that were initiated in the back-wall layers had developed until the front-face layers due to significant delamination.

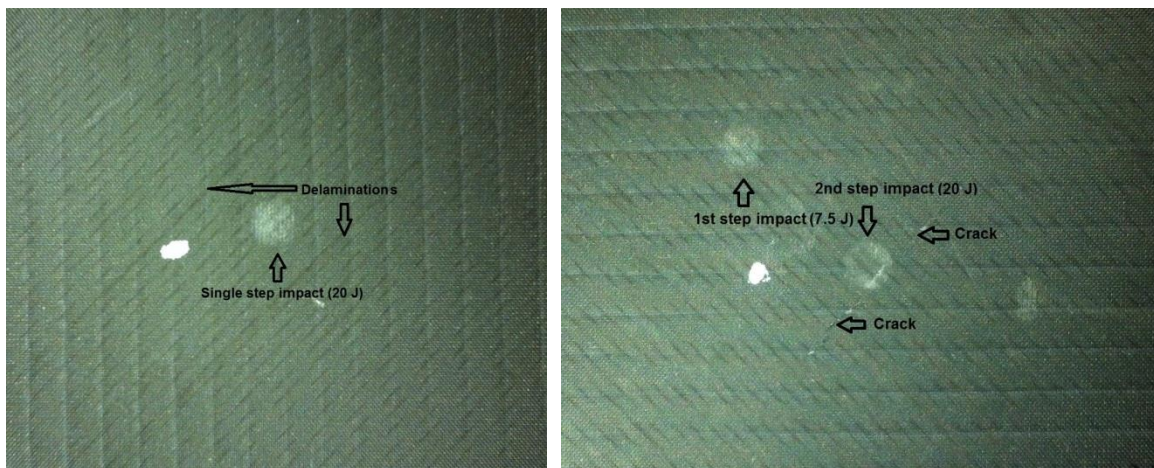

Figure 5. Typical images for epoxy/CFRC (left) and SiO₂/rubber/epoxy CFRC (right) samples demonstrating delamination visible by naked eye following impact tests.

3.2. Compression after Impact (CAI) test

The CAI test average results for single step impacted samples are listed in Table 1.

Table 1. Compression after impact results of the single step impacted samples .

Sample	F (kN)	CAI (MPa)	Impact Energy (J)
Epoxy/CFRC	53.348	133	20
SiO ₂ /rubber/epoxy CFRC	54.91	137	20

Comparing the nano enhanced samples and the unenhanced ones after the single step high velocity impact; no improvement in the residual compressive strength is observed which shows that the nanosilica enhancement and toughening is not useful in high energy impacts. That is because high velocity impact properties are fibre architecture dominant [5] and since the fibre lay-up for both types of samples are same; the residual compressive strength after the high velocity impact is almost equal. The CAI test average results for double step impacted samples after the second step impact are listed in Table 2. It can be understood from Table 2 that the nanosilica enhanced samples got more CAI strength than the SiO₂/rubber/epoxy CFRC samples after the second step high energy impact. As it was conclude from the C-scan results, using SiO₂ nanoparticles with rubber particles for matrix

enhancement makes the epoxy/CRFC more damage tolerance and less susceptible to the low energy impact damage such as that caused by a tool drop on the structure.

Table 2. Compression after impact results of the double step impacted samples.

Sample	F (kN)	CAI (MPa)	1 st Step Energy (J)	2 nd Step Energy (J)
Epoxy/CFRC	43.833	109.25	7.5	20
SiO ₂ /rubber/epoxy CFRC	57.252	142.5	7.5	20

The present results show a greater influence of resin toughness over impact damage extent, than over growth of delaminations in compression. Comparing the average residual compressive strength of the nanosilica enhanced samples after the double step impact (142 MPa) with one for the standard samples (109 MPa), about 30% improvement in the strength can be observed. While comparing the average delamination area of the nanosilica enhanced samples ($\pi 14.2^2 \text{ mm}^2$) with the standard ones ($\pi 20.6^2$), there is about 50% smaller delamination area for the nanosilica enhanced composite. These results agree to those of Cartie & Irving [6]. Considering the residual compressive strength of the SiO₂/rubber/epoxy CFRC samples after the single step impact and the double step one, it can be observed that SiO₂/rubber/epoxy CFRC samples after the single step impact have got less compressive strength than the double step impacted ones which is not expected [7,8]. Probably the damage caused by the low energy first step impact has a damping effect against the second step high energy impact for nanosilica and rubber enhanced composite. This effect is seen just in the enhanced samples and not in the unenhanced ones. Therefore this effect is emerged because of nano and rubber particle enhancement that increase toughness and impact resistance of the composite matrix, but need to be investigated further.

4. Conclusions

This study investigated impact tolerance of carbon fibre reinforced epoxy composite and the effect of silica nanoparticles and rubber particles enhancement on improvement of the impact resistance. The impact tolerance was evaluated utilizing compression after impact test after the impact by Gas-gun impacting equipment. Conclusions derived are listed below:

1. Ultrasonic C-scan of the specimens impacted at 7J shows that nanosilica and rubber enhanced specimens have about 50% smaller delamination area than the unenhanced specimens.
2. Compression after impact test results for single-step impacted specimens' show that nanosilica and rubber enhancement is not effective for impact resistance against high velocity impacts since high velocity impact properties are fibre architecture dominant and matrix properties has little effect.
3. Comparing the CAI test results for the double step impacted nano-enhanced and standard CFRP samples, about 30% improvement in residual compressive strength for the nanosilica and rubber particles enhanced composite is obtained for low velocity impacts. This impact resistant enhancement will help the rear wing to be more damage tolerant against low energy impact and keeps the aerodynamic efficiency of the part as high as possible.

References

- [1] Cox P C (McLaren), McGrath G C (TWI) and Savage G M (McLaren) 1993 Designing with fibre reinforced composites to provide energy absorption mechanisms in damage tolerant Formula 1 cars, *ICCM-9*
- [2] Njuguna J, Pielichowski K and Alcock J R 2007, Epoxy-Based Fibre Reinforced Nanocomposites, *Adv Eng Mater* **9**, No. 10, : 835-847.
- [3] Shen Q, Omar M, Dongri S 2012, Ultrasonic NDE Techniques for Impact Damage Inspection on CFRP Laminates, *J Mater Sci Resear* **Vol. 1**, No. 1.p2.
- [4] Standard Test Method for Compressive Residual Strength Properties of Damaged Polymer Matrix Composite Plates, *ASTM D 7137/D 7137M – 07*.
- [5] Kinloch A J, Masania K, and Taylor A C 2009, The Fracture of Nanosilica and Rubber Toughened Epoxy Fibre Composites. *COMPOSITES & POLYCON 2009 American Composites Manufacturers Association*
- [6] Cartie D D R, Irving P E 2002, Effect of resin and fibre properties on impact and compression after impact performance of CFRP, *Elsevier Composites: Part A* **33** 483-93.
- [7] Njuguna, J (Ed.). *Structural Nanocomposites: Perspectives for Future Applications*. Springer Berlin Heidelberg. 2013.
- [8] Njuguna J, Silva F, Sachse S. Nanocomposites for vehicle structural applications; In *Nanofibers - Production, Properties and Functional Applications*, Tong Lin (Ed.), 2011. ISBN: 978-953-307-420-7, DOI: 10.5772/23261.